



Gear Units, M-N Series

Edition 09/2009
OIMEX 0103/0909

Operating Instructions



Contents

1	How To Use This Manual.....	5
2	Unit Designation.....	6
2.a	Detailed unit designation.....	6
2.b	Nameplate unit designation.....	7
3	Part List of Standard Type Gear Units.....	8
3.a	M... Type.....	8
3.b	N... Type.....	9
4	Thinks to Check Before the Gear Unit or Geared Motor is Installed.....	10
4.a	Safety notes.....	10
4.b	Transportation.....	11
4.c	Storage.....	11
5	Installing The Gear Unit.....	12
5.a	Before you start.....	12
5.b	Check Name Plate.....	12
5.c	Check the ambient conditions and temperature.....	12
5.d	Check fitting elements and the shaft dimensions to fit.....	11
5.e	Check the voltage supply.....	12
5.f	Check the mounting position.....	14
5.g	Use the breather plug.....	14
5.h	Check the oil level.....	14
5.i	Check shaft ends and mounting faces.....	14
5.j	Cover abresive ambient.....	14
5.k	Check accessibility to filling, breather and drain plugs.....	15
6	Mechanical Installation.....	16
6.a	Installing gear units in category II2G/D-II3G/D.....	16
6.b	Fitting outputshaft elements.....	17
6.c	Correct position of outputshaft elements.....	17
6.d	Fitting Couplings.....	18
7	Inspections.....	19
8	Lubrication.....	20
8.a	Oil Types.....	20
8.b	Oil Quantities.....	21
8.c	Mounting Positions.....	24
9	Troubleshooting Guide.....	26
9	Decleration by the Manufacturer	30



10	Waranty conditions	31
11	Waranty	32
12	Service Contact Points	33



1 -How To Use This Manual

Take attention to the following safety and warning signs for proper understanding and quick reference.



Electric Hazard; Can cause severe or fatal injuries.



Mechanical Hazard; Can cause severe or fatal injuries.



Likely to be Hazardous; Can cause minor injuries



Damage Risk; Can damage the drive or environment



Important Information



Important information about explosion protection

The operating instructions contain important information to ensure;

- Trouble-free operation
- Fulfilment of any rights to claim under guarantee

The operating instruction must be kept close to the gearbox and must be available in case it is needed.

This operating instruction is written for MN/NN/MT/NT -ATEX series gear units and is applicable only for these series. If any different type of gearbox is used please ask YILMAZ REDUKTOR for the operating instructions of that type.

This instruction can be used only for standard type geared units of YILMAZ REDUKTOR. For special application and modified gear units ask YILMAZ REDUKTOR for validity.

The MN/NN/MT/NT Series garboxes are with standard IEC B5/B14 connection flange and without motor. The electric motor which will be connected to the gearbox must also be in conformity with the ATEX (94/9/EC) standarts.

All the external parts which will be assembled to the gear unit must conform ATEX (94/9/EC). The product this declaration refers to must not be put into service until the machinery into which it is to be incorporated has been declared in conformity with the provisions of the relevant European Directives.

If the gear unit is not operated as informed on this manual the gear unit is no longer ATEX conforming and YILMAZ REDUKTOR does not take any responsibility.



2 -Unit Designation

a- Detailed unit designation



Detailed M/N series gear units designation for ordering

(This Designation is different from the short nameplate designation)

3,0kW - 29rpm - 48,86 - MN373 - A09

Power (kW)

Output
Speed(rpm)

Ratio (i)

Type

Motor Size

MN -Foot mounted type with IEC flange without motor
NN -Flange mounted type with IEC flange without motor
MT- Foot mounted without motor
NT- Flange mounted without motor

A07- IEC 71 B5
A08- IEC 80 B5
A09- IEC 90 B5
A10- IEC 100 B5
A11- IEC 112 B5
A13- IEC 132 B5

A16- IEC 160 B5
A18- IEC 180 B5
A20- IEC
200 B5
A22- IEC 220 B5
A25- IEC 250 B5

Examples

58,09-MN373-A08

MN373 foot mounted type geared with IEC80 B5 motor connection flange.

10,15-NN373-A08

NN373 i=10,15, flange mounted type geared unit with IEC 80 type B5 flange

10,15-NT373

NT373 i=10,15, flange mounted type geared unit with solid input shaft





b- Nameplate, unit designation



Nameplate unit designation is a short abbreviation from the detailed designation

A sample name plate for M/N Series

 YILMAZ REDÜKTÖR A.S. Beylikdüzü SAN - BİR Bulvarı 1.Bölge 3.Cadde No:18 34900 Büyükçekmece / İST. / TURKEY		
Type: MN373-A09 / 2GD		
S/N.: 04 / 2251 - EX		IP65
P :1,5 kW	M ₂ : 843 Nm	
n ₁ :1400 rpm	n ₂ : 16 rpm	
F _{R2} :9542 N	F _{R1} : - N	
F _{A2} :190 N	F _{A1} : - N	
Oil :VG 220	Qty : 4 lt	
M.Pos.: B3	T _a : -20/+40 °C	
 II 2GD c,k T4 / T120 °C		

Abbreviations:

Type. : Type of gearbox

S/N: Serial Number of gear unit as; year/order no-Ex

IP.: Enclosure

P : Max. Allowed Power

M2: Output torque

n1: Input speed

n2: Output speed

FR2: Max. allowed radial load at output shaft

FR1: Max. allowed radial load at input shaft

FA2: Max. allowed axial load at output shaft

FA1: Max. allowed axial load at input shaft

Oil: Filled oil inside the gear unit

Qty.: Oil quantity

M.pos.: Mounting Position.

Ta: Ambient Temp

ATEX sign (EN 13463-1):

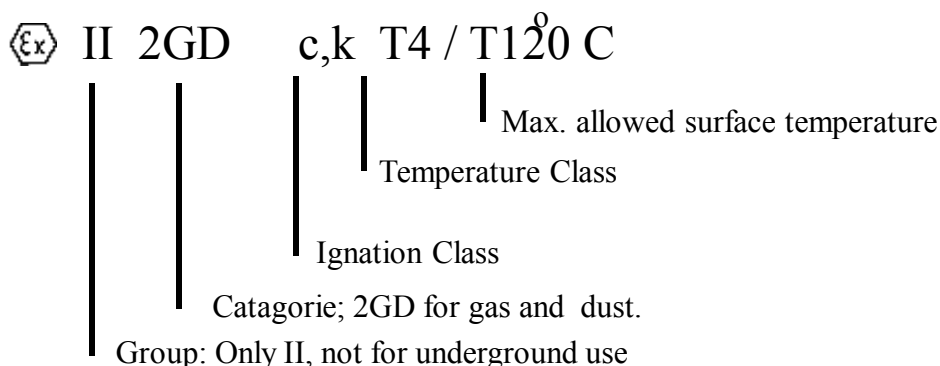



3- Part List of Standard Type Gear Units a- M... Types

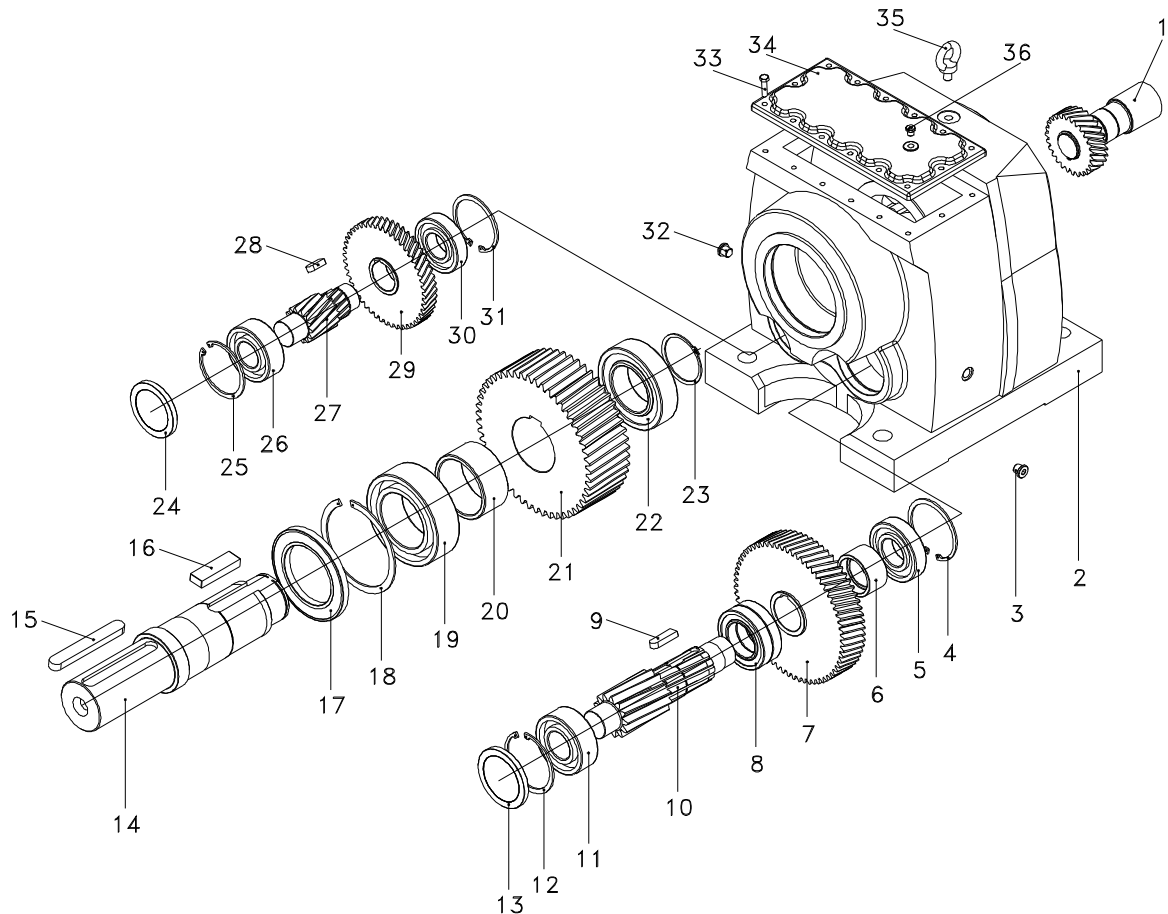

Standard M... type basic part diagram. Parts may differ for special applications.

Standard Part List

1- Pinion	9- Key	17- Oil Seal	25- Circlip	33- Bolt
2- Housing	10- Pinion Shaft	18- Circlip	26- Bearing	34- Cover Plate
3- Plug	11- Bearing	19- Bearing	27- Pinion Shaft	35- Eye Bolt
4- Circlip	12- Circlip	20- Spacer	28- Key	36- Plug
5- Bearing	13- Closing Cap	21- Gear	29- Gear	
6- Spacer	14- Output Shaft	22- Bearing	30- Bearing	
7- Gear	15- Key	23- Circlip	31- Circlip	
8- Bearing	16- Key	24- Closing Cap	32- Plug	



b- N... Types

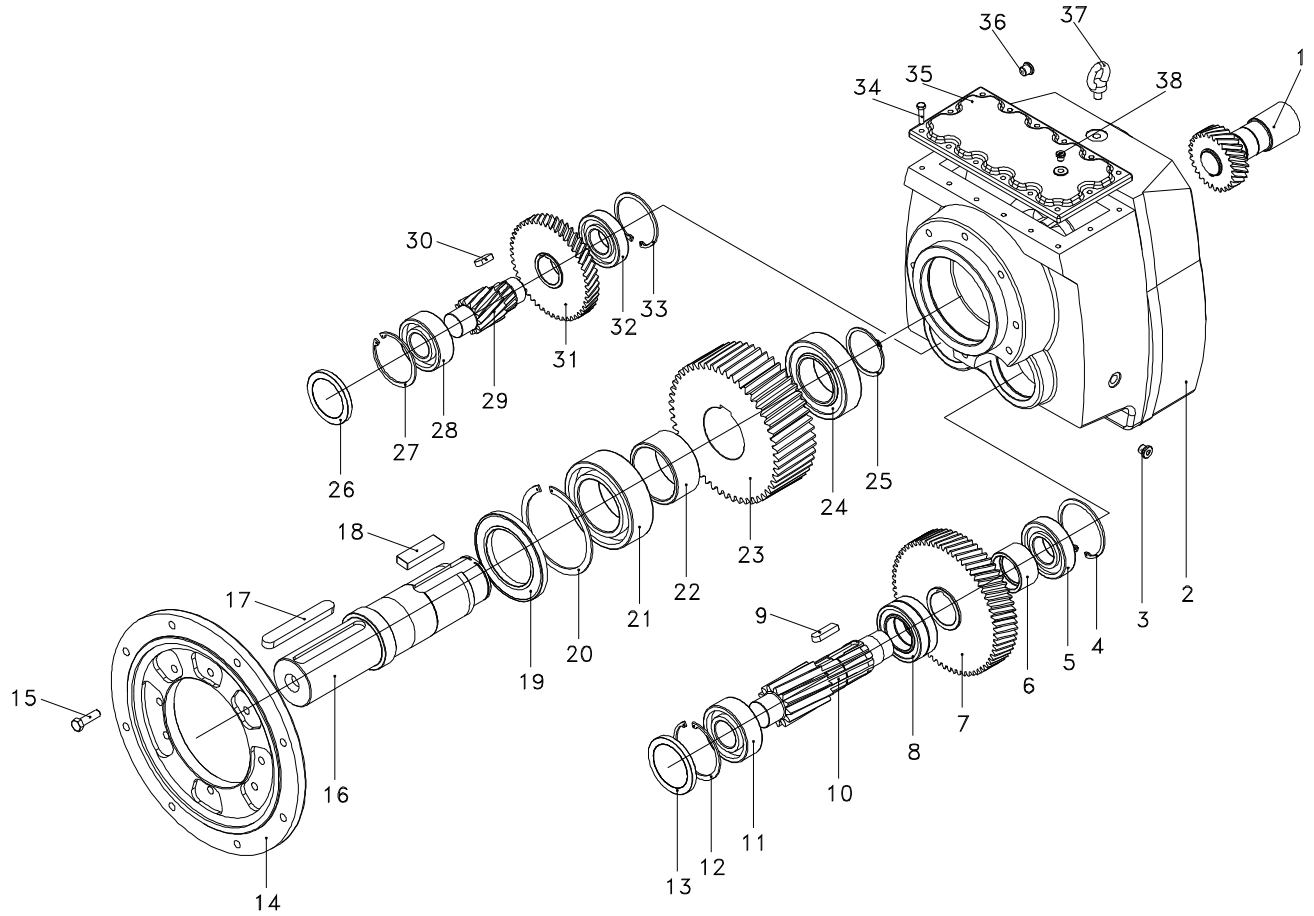

Standard N... type basic part diagram. Parts may differ for special applications.

Standard Part List

1- Pinion	9- Key	17- Key	25- Circlip	33- Circlip
2- Housing	10- Pinion Shaft	18- Key	26- Closing Cap	34- Bolt
3- Plug	11- Bearing	19- Oil Seal	27- Circlip	35- Cover Plate
4- Circlip	12- Circlip	20- Circlip	28- Bearing	36- Plug
5- Bearing	13- Closing Cap	21- Bearing	29- Pinion Shaft	37- Eye Bolt
6- Spacer	14- Output Flange	22- Spacer	30- Key	38- Plug
7- Gear	15- Bolt	23- Gear	31- Gear	
8- Bearing	16- Output Shaft	24- Bearing	32- Bearing	



4 -Thinks to Check Before the Gear Unit or Geared Motor is Installed

a) Safety notes for use in potentially explosive atmosphere



Explosive gas mixtures or concentration of dust can lead to severe or fata injuries in conjunction with hot or moving parts of the gear unit / gearmotor

Before you install the gearbox you have to be sure that the gearbox is arrived with the all necessary equipment and without damage. Thinks to take into consideration before you start to install the unit;

- You have received the correct operation manual of the your product.
- The gearbox and all its parts are transported without damage.
- The gearbox is stored correctly according the instructions in this manual
- The nameplate is clearly visible and all the data can be read.
- All the regulations and requirements according to the currently valid national/regional regulations.
- The gearbox is used according its intended use



Intended use of gearbox:

The gearboxes covered by this manuel can only be used in ATEX zone 2G,2D,3G,3D and ignition class IIA/IIB.

The gear units are intended for industrial systems and may only be used in accordance with the information provided in this manual and the nameplate of the gearbox. They comply with the applicable standards and regulations and meet the requirements of the directive 94/9/EC. The gearbox is started up, maintained and operated according this manual. The gearbox is incorporated with 94/9/EC confirming parts/machines.



A motor connected to the gear unit is only allowed to be operated in the frequency entries so that the data provided on nameplate of the gear unit is not exceeded and is accordance with the nameplate. The input speed range will be provided on the name plate if YILMAZ REDUKTOR is informed that the gear unit will be used with frequency inverter. If not informed the nameplate will have a single fixed input speed and only this input speed is allowed.

The electric motor and frequency inverter must be in accordance with 94/9/EC



If the gear units input is used with variable speed gear unit, this must be informed to YILMAZ REDUKTOR before ordering and on the nameplate the allowed maximum and minimum input speeds (speed range) will be provided. If not mentioned by ordering the gear units input speed will be a fixes single input speed and only this speed is allowed.



If the gear unit will be driven by belt / coupling / chain drive etc. the gear unit is onlt allowed to be used according the nameplate entries. Diffrent speed, higher motor power, higher radial/axial loads etc. than nameplate is not allowed.



The ambient conditions must be accordance with the name plate and no agresive media must attack the paint and seals.



The gearbox maintenance (oil change / check) must be done according this manuel

b) Transportation

When the goods arrive, first check for any damage. If some damage observed, immediately contact the transport company and inform about the damage. Contact YILMAZ for the damage and do not start to install the unit until it is agreed that the damage has no affect of operation.



Use the supplied eyebolts or lifting holes for lifting up the gear unit. The eyebolts are capable to carry the weight of gearboxes only. Do not hang additional loads.

c) Storage

If the geared unit or gearedmotor will be stored up to 3 years refer to the following instructions;

With Packing;

-Use corrosion protection oil for the output shaft and connection surfaces like flange surface or foot assembling surface. Seal the unit in a plastic wrap and pack it in container. A moisture indicator should be placed around the container to observe the moisture. Relative atmospheric humidity should not exceed 50%. The container should be kept under roof which protects from snow and rain. Under this condition the gear unit can be stored up to 3 year with regular check.

Without Packing;

-Use protection oil for the output shaft and connection surfaces like flange surface or foot assembling surface. If no packing is used and the gearbox is stored without packing, the ambient temperature should be between 5 to 60 Celsius degrees. The gearbox must be kept under enclosed roof with constant temperature and constant humidity not exceeding 50%. The storage should be free of dust and dirt and ventilated with filter. If the gearbox is stored without packing it is recommended not to store more than 2 years and regular check during this time is recommended.

If stored in open protect against insect damage.



5- Installing The Gear Unit

a) Before you start;

- Observe the gear unit for damages of storage or transportation. If any damage please contact YILMAZ REDUKTOR.
- Be sure that you have all the equipment necessary for installing like; Spanners, torque wrench, shims and distance rings, fixing devices for input and output elements, lubricant, bolt adhesive/locktide etc.



b) Check nameplate of the gear unit;

- ATEX conforming gear gear units have a nameplate indicating the “EX” sign shown on the left side and the following information;
 - Equipment group
 - Ex category
 - Ex zone
 - Temperature class
 - Maximum surface temperature

If you can not see this sign and values, your gearbos is not intended for use on potentially explosive atmosphere. If some of the data can not be read because of some reason, please contact YILMAZ REDUKTOR.

c) Check the ambient conditions and temperature;

Have measures been taken to ensure that no potentially explosive atmosphere, oils, acids, gases, vapors or radiated interference are present when the gear unit is being installed.

The ambient temperature must be in accordance with the oil tables given on the manual. If different contact YILMAZ REDUKTOR for special solutions.



The ambient air temperature must not exceed 40 degrees celcius as mentioned on the nameplate. The cooling air surrounding the gear unit must bellow 40 degrees and the gear unit must not subject to heating from external sources. The gear unit surface must be kept clean and sufficiently ventilated.

d) Check fitting elements and the shaft dimensions to fit;

All external elements that will be fitted to the gear unit must be ATEX confirming.

The shaft/flange dimation are shown bellow. Use correct tolerances to fit external elements. Observe the assembly instructions provided in this manual.



Only belts with sufficient shunt resistance $<10^9$ ohm are allowed



Never strike belt pulleys, coupling, pinions etc. with a hammer when pulling them onto the shaft end. This could result in damage to bearings, the housing and the shaft.

Power transmission elements must be balanced after fitting and must not give rise to any impermissible radial or axial forces.



Observe the name plate for maximum allowed radial and axial load. The external radial and axial load must not exceed the provided values on the nameplate.

Type	Output Shaft Diameter	Output Shaft Tolerance (DIN748) Up to 50mm k6 Over 50mm m6	Flange Centering Shoulder Diameter (N type only)	Centering Shoulder Tolerance (g6) (N type only)
M/N...002/003..	20	+0.02 0	95	-0.01 -0.04
M/N...102/103...	25	+0.02 0	110	-0.01 -0.04
M/N...172/173...	25	+0.02 0	110	-0.01 -0.04
M/N...202/203...	30	+0.02 0	130	-0.02 -0.04
M/N...272/273...	35	+0.02 0	130	-0.02 -0.04
M/N...282/283...	35	+0.02 0	130	-0.02 -0.04
M/N...372/373...	40	+0.02 0	180	-0.02 -0.04
M/N...472/473...	50	+0.02 0	230	-0.02 -0.05
M/N...502/503...	60	+0.03 +0.01	250	-0.02 -0.05
M/N...602/603...	70	+0.03 +0.01	300	-0.02 -0.05
M/N...702/703...	90	+0.04 +0.02	350	-0.02 -0.06
M/N...872/873...	110	+0.04 +0.02	450	-0.02 -0.06
M/N...972/973...	120	+0.04 +0.02	550	-0.02 -0.06



e) Check the voltage supply;

ATEX Conforming gear units are supplied by YILMAZ without motor. The motor that will be fitted must have ATEX certificate and the instruction manual of the electric motor provider must be observed. Observe the name plate of the electric motor and the instructions of the supplier. Use experienced electric technician. The gearbox and the motor must be grounded to prevent potential differences of earth and gearbox/motor.



Using wrong connection or voltage can damage the electric motor or environment.
The electric connection must be done by experienced electric technician.

f) Check the mounting position;

The mounting position must be in accordance with the mounting position mentioned on the name plate. If different please contact YILMAZ REDUKTOR for possibilities of using in a different mounting position. Different use of mounting position than indicated on the name plate without informing YILMAZ REDUKTOR will cancel the ATEX conformity and YILMAZ does not take any responsibility.



Do not mix synthetic oils with mineral oils which can cause serious damage on the gear unit.

g) Use of breather plug;

Breather plugs are supplied as a standard part for ATEX conforming gear units. The breather plug is attached to the gear unit and must be changed with the most top plug according to the mounting position. Take out the plug over the gear box and replace it with the supplied breather plug after assembling to its place and before start-up.



All plug points are not machined. Only plugs according mounting position is machined. If no mounting position is mentioned by ordering the standard B3 position plugs are machined.





h) Check the oil level ;

On the mounting position tables the oil level plug is shown. Please refer to those tables and be sure that the oil level is correct according the mounting position. Use a wire as shown below for checking the oil level entering from the level plug. The oil level must be within 3mm from the plugs entering point as shown below. If you need to adjust the oil level refer to the oil tables given on this manuel and be sure you are using the correct oil. Observe the nameplate for the correct oil.



Do not mix synthetic oils with mineral which can cause serious damage on the gear unit.

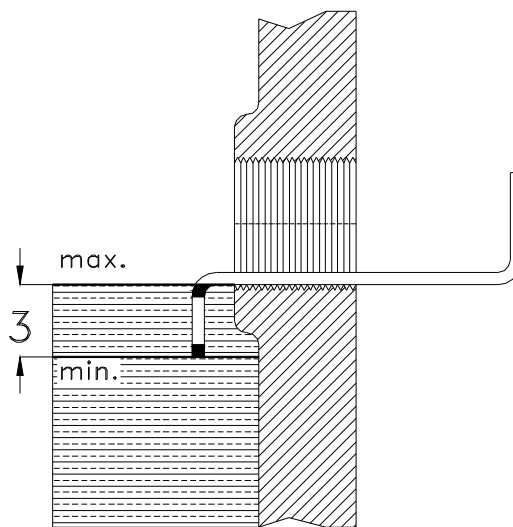

i) Check shaft ends and mounting faces;

Before you start to installing be sure that all the connection elements are free of oil and dust. The output shaft may be protected by anti-corrosion oil. Please remove this using available solvents on your market. By using this do not touch sealing lips or painting of the housing.

j) Cover abrasive ambient;

If the gear unit will be placed on a abrasive ambient be sure that the output seals are covered so that no abrasive material, chemicals or water touches the seals. Any pressure coming from outside over the seals can cause that the out staying substances to enter the gearbox and cause serious damage to the gear unit. If pressure or abrasive material can not be prevented from coming over the sealing, contact YILMAZ for solutions.



Abrasive material, chemicals, water, positive or negative pressure exceeding 0,2 bar can affect or damage the sealing lip or output shaft. Inside entering substances from the seals can cause serious damage to the gear unit.

k) Check accessibility to filling, breather and drain plugs;

The filling, breather and drain plugs must be freely accessible for further checking and service.



6- Mechanical Installation

The mounting plate must be rigid enough not allowing torsions, flat enough to prevent strains by tightening the bolts and stable enough not allowing vibrations. By using chain drives this becomes much more important because of the polygon effect on chain drives. According to your connection elements the maximal permitted radial and axial load of the gear unit must be in accordance with your application. Check the product catalogue for permitted radial loads and calculation.



If the output or input shaft is overloaded by radial or axial loads it can cause serious damage to the gear unit.

Secure the gear unit using 8.8 or higher quality bolts.



All bolts are locked by use of locktite adhesives or gear-shims on the gearbox. By assembling the gear unit locktides adhesives or gear-shims must be used to prevent loosening of bolts.



Cover all the turning parts from human entering or touching. Turning parts can cause severe or fatal injuries.

For different kind of basic installations refer to the following illustrations.



Only ATEX-approved input and output elements are allowed to be used, assuming the elements are subject to Directive 94/9/EC

a- Installing gear units in category II2G/D-II3G/D

Explosion-proof gear units comply with the design requirements for unit group II, category 2G,2D,3D,3G. These units are intended for use in zones 1 and 21.



The gear units in category II2D must be used in ambient temperature between -20 C to +40 C only. If different ambient conditions this must be informed before order and the name plate must be in accordance with the ambient conditions.



The temperature class depends on the speed, type and mounting position of the gearbox and is indicated on the name plate. Temperature classes from T4 to T6 are provided by YILMAZ REDUKTOR.



The surface temperature of the gearbox must not exceed the provided max. surface temperature on the name plate. After all installations finished and the gearbox is started up according this manual let the gear unit run 4 hours at full load and check the surface temperature from the shown point bellow and the ambient temperature. Check the following:

$(40-T_a)+T_w < T_{max.}$ of nameplate (T_a : Ambient Temp., T_w : Surface Temp)



If the result is higher than T_{max} , immediately stop the system and contact YILMAZ REDUKTOR.

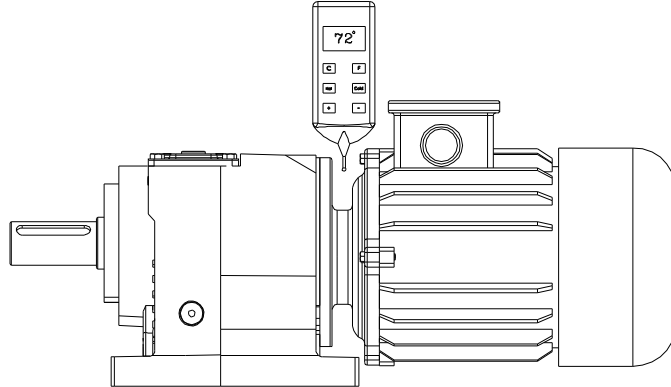

b- Fitting outputshaft elements

Use the following illustration to assemble output shaft units

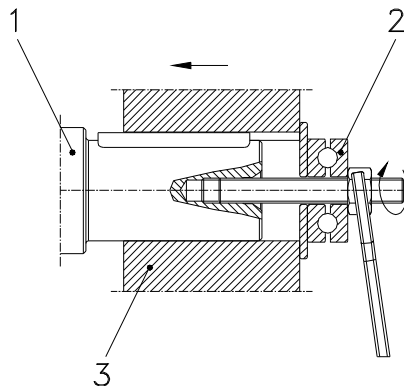

- 1) Gear shaft end
- 2) Thrust bearing
- 3) Coupling hub

c- Correct position of outputshaft elements

The Output Shaft unit (transmission elements) must be placed as close as possible to the gear unit so that the radial load is as close as possible to the gear unit.

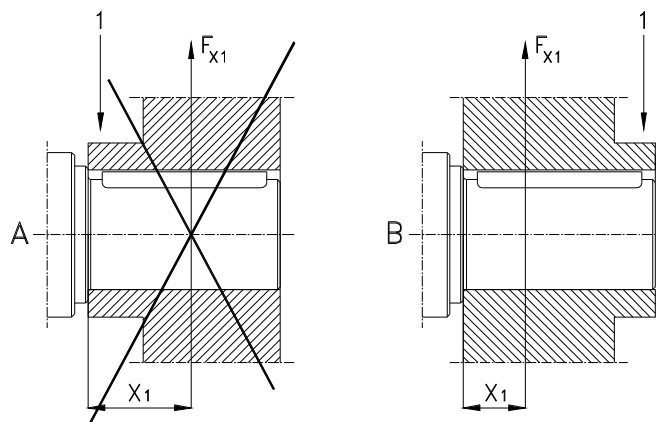

- 1) Hub



d- Fitting Couplings

d1-By fitting couplings be sure that there is some clearanve between the two elements

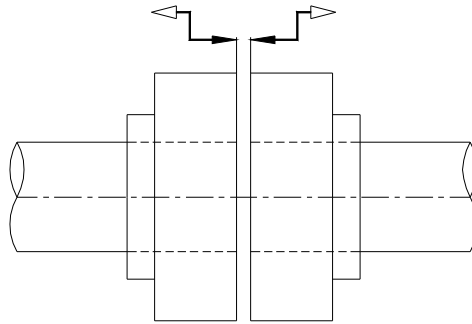

d2-By fitting couplings be sure that there is no exantricity between the two shafts.

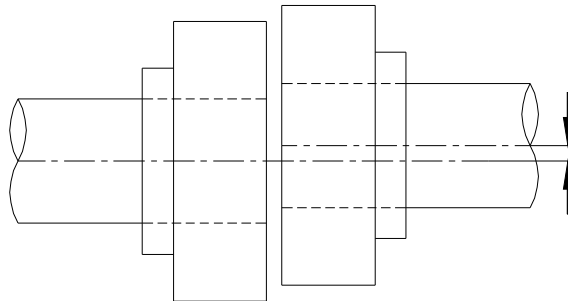

d3-By fitting couplings be sure that the two shafts are not angular miss-aligned.

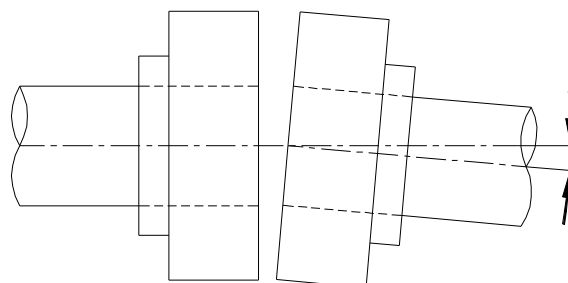



7- Inspections

Under normal ambient and working conditions the gear unit should be checked according the following intervals. (For definition of normal working conditions refer to the product catalogue: “Selecting Gearbox” section);

Item to check / replace	Every 3.000 working hours or every 6 months	Every 4.000 working hours	Every 10.000 working hours or every 3 years	Every 25.000 working hours
Check for oil leakage	x			
Check for oil level	x			
Check oil leakage from seal	x			
Check Rubber buffer	x (Change if necessary)			
Check Bearings Noise		x (Change if necessary)		
Change Mineral Oil			x (See Below for details)	
Change Synthetic-PAO Oil				x (See Below for details)
Change Sealing				x
Change Bearing Grease				x
Change Bearings				x
Check for noise Changes				x

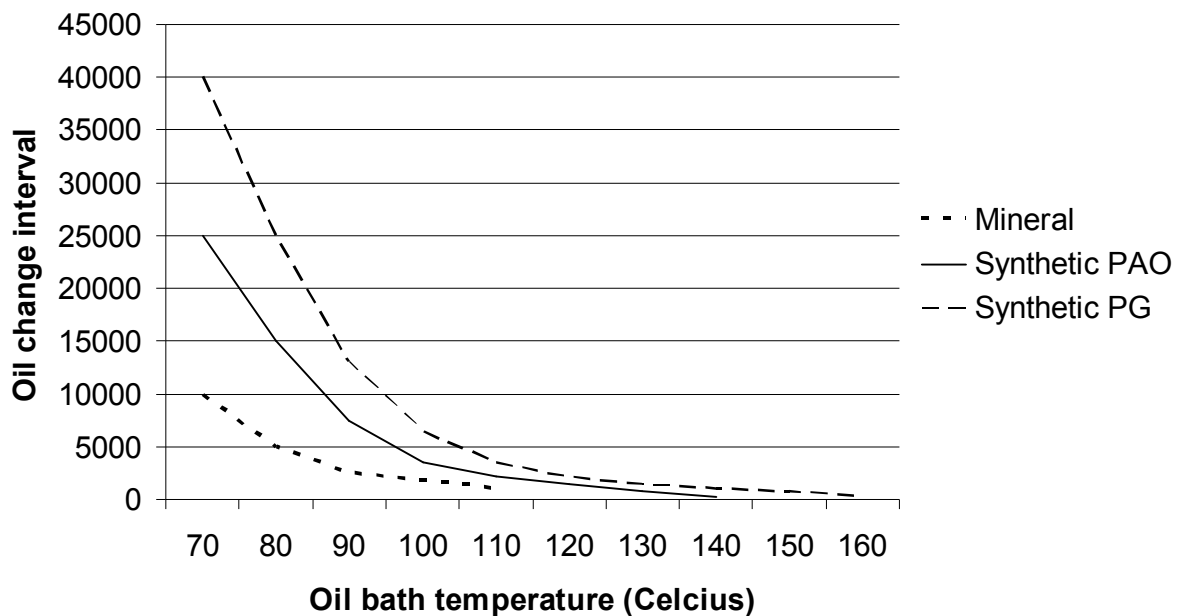







For normal ambient conditions 70 degrees Celcius Should be taken as reference

* For K series Mineral oil is used unless it is differently ordered. For oil type and quantities refer to the following tables.



8- Lubrication
a- Oil Types

Lubricant	Usage Temperature	ISO Viscosity Class							
Synthetic Oil	-20 ... +140	ISO VG 680	Degol GS 680	Enersyn SG-XP680		Syntheso D 680 EP	Gylgoyle HE 680		
	-20 ... +140	ISO VG 460	Degol GS 460	Enersyn SG-XP460	Glycolube 460	Syntheso D 460 EP	Gylgoyle HE 460	Tivela SD	Alphasyon PG 460
	-25 ... +140	ISO VG 320	Degol GS 320	Enersyn SG-XP320	Glycolube 320	Syntheso D 320 EP	Gylgoyle HE 320		Alphasyon PG 320
	-25 ... +140	ISO VG 220	Degol GS 220	Enersyn SG-XP220		Syntheso D 220 EP	Gylgole HE 220	Tivela WB	Alphasyon PG 220
	-30 ... +140	ISO VG 150	Degol GS 150	Enersyn SG-XP 150		Syntheso D 150 EP			Alphasyon PG 150
	-30 ... +140	ISO VG 100		Enersyn SG-XP 100		Syntheso D 150 EP			
Synthetic Grease	-30 ... +100					ISOFLEX Topas L152	Mobiltemp SHC 100	Cassida RLS 00	

Operating Instruction

M Series

Oil Types



b- Oil Quantities. (lt)

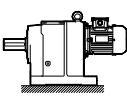
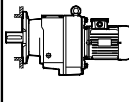
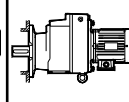
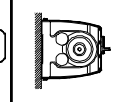
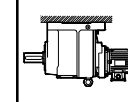
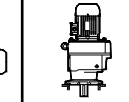
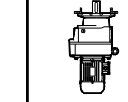
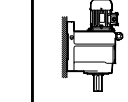
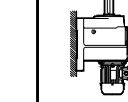





Type									
	B3	B5	B51	B6-B7	B8	V1	V3	V5	V6
MR002/003	0,40/0,35	-	-	0,45/0,40	0,45/0,40	-	-	0,5/0,45	0,5/0,45
MR102/103	0,65/0,60	-	-	0,65/0,60	0,65/0,60	-	-	0,83/0,75	0,83/0,75
MR172/173	0,70/0,65	-	-	0,70/0,65	0,70/0,65	-	-	0,85/0,80	0,85/0,80
MR202/203	1,20/1,1	-	-	1,55/1,4	1,55/1,4	-	-	1,9/1,8	1,9/1,8
MR272/273	1,10/1,0	-	-	1,35/1,2	1,35/1,2	-	-	1,75/1,68	1,75/1,68
MR282/283	1,70/1,6	-	-	2,1/1,9	2,1/1,9	-	-	2,8/2,5	2,8/2,5
MR372/373	2,0/1,9	-	-	2,8/2,6	2,8/2,6	-	-	3,1/2,7	3,1/2,7
MR472/473	4,3/4,0	-	-	5,5/5,0	5,5/5,0	-	-	7,0/6,7	7,0/6,7
MR502/503	7,0/6,0	-	-	9,5/8,5	9,5/8,5	-	-	11,7/11	11,7/11
MR602/603	10/8,5	-	-	13,5/12,5	13,5/12,5	-	-	18,4/17	18,4/17
MR702/703	16/16	-	-	22,5/21	22,5/21	-	-	35/32	35/32
MR872/873	37/20	-	-	37/35	37/35	-	-	45/41	45/41
MR972/973	53/50	-	-	53/50	53/50	-	-	60/55	60/55
NR002/003	-	0,60/0,55	0,60/0,55	-	-	0,60/0,55	0,60/0,55	-	-
NR102/103	-	0,95/0,80	0,95/0,80	-	-	0,95/0,80	0,95/0,80	-	-
NR172/173	-	0,95/0,90	0,95/0,90	-	-	0,95/0,90	0,95/0,90	-	-
NR202/203	-	2,1/2,0	2,1/2,0	-	-	2,1/2,0	2,1/2,0	-	-
NR272/273	-	2,0/1,6	2,0/1,85	-	-	2,0/1,85	2,0/1,85	-	-
NR282/283	-	3,0/2,85	3,0/2,85	-	-	3,0/2,85	3,0/2,85	-	-
NR372/373	-	3,4/3,3	3,4/3,3	-	-	3,4/3,3	3,4/3,3	-	-
NR472/473	-	8,0/7,6	8,0/7,6	-	-	8,0/7,6	8,0/7,6	-	-
NR502/503	-	12,8/11,7	12,8/11,7	-	-	12,8/11,7	12,8/11,7	-	-
NR602/603	-	22,5/20,15	22,5/20,15	-	-	22,5/20,15	22,5/20,15	-	-
NR702/703	-	35/32	35/32	-	-	35/32	35/32	-	-
NR872/873	-	50/48	50/45	-	-	50/45	50/45	-	-
NR972/973	-	93/95	60/55	-	-	60/55	60/55	-	-

Operating Instruction

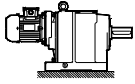
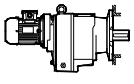
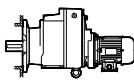
M Series

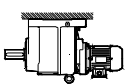
Oil Quantities





Type									
	B3	B5	B51	B6-B7	B8	V1	V3	V5	V6
MR284	1,9 / 0,7	-	-	1,9 / 0,7	1,9 / 0,7	-	-	2,8 / 0,7	2,8 / 0,7
MR374	2,6 / 0,7	-	-	2,6 / 0,7	2,6 / 0,7	-	-	3,1 / 0,7	3,1 / 0,7
MR474	5,0 / 1,5	-	-	5,0 / 1,5	5,0 / 1,5	-	-	7,0 / 1,5	7,0 / 1,5
MR504	8,5 / 1,5	-	-	8,5 / 1,5	8,5 / 1,5	-	-	11,7 / 1,5	11,7 / 1,5
MR604	12,5 / 4,0	-	-	12,5 / 4,0	12,5 / 4,0	-	-	18,4 / 4,0	18,4 / 4,0
MR704	21 / 4,0	-	-	21 / 4,0	21 / 4,0	-	-	35 / 4,0	35 / 4,0
MR874	35 / 4,0	-	-	35 / 4,0	35 / 4,0	-	-	45 / 4,0	45 / 4,0
MR974	50 / 4,0	-	-	50 / 4,0	50 / 4,0	-	-	60 / 4,0	60 / 4,0
NR284	-	2,85 / 0,7	2,85 / 0,7	-	-	2,85 / 0,7	2,85 / 0,7	-	-
NR374	-	3,3 / 0,7	3,3 / 0,7	-	-	3,3 / 0,7	3,3 / 0,7	-	-
NR474	-	7,6 / 1,5	7,6 / 1,5	-	-	7,6 / 1,5	7,6 / 1,5	-	-
NR504	-	11,7 / 1,5	11,7 / 1,5	-	-	11,7 / 1,5	11,7 / 1,5	-	-
NR604	-	20,1 / 4,0	20,1 / 4,0	-	-	20,1 / 4,0	20,1 / 4,0	-	-
NR704	-	32 / 4,0	32 / 4,0	-	-	32 / 4,0	32 / 4,0	-	-
NR874	-	45 / 4,0	45 / 4,0	-	-	45 / 4,0	45 / 4,0	-	-
NR974	-	60 / 4,0	60 / 4,0	-	-	60 / 4,0	60 / 4,0	-	-

Operating Instruction

M Series

Oil Quantities

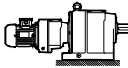
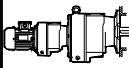
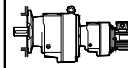
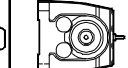
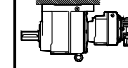

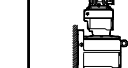
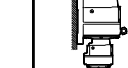
Type									
	B3	B5	B51	B6-B7	B8	V1	V3	V5	V6
MR275/276	1,2 / 0,5	-	-	1,2 / 0,5	1,2 / 0,5	-	-	1,75 / 0,5	1,75 / 0,5
MR285/286	1,9 / 0,5	-	-	1,9 / 0,5	1,9 / 0,5	-	-	2,8 / 0,5	2,8 / 0,5
MR375/376	2,6 / 0,85	-	-	2,6 / 0,85	2,6 / 0,85	-	-	3,1 / 0,85	3,1 / 0,85
MR475/476	5,0 / 1,9	-	-	5,0 / 1,9	5,0 / 1,9	-	-	7,0 / 1,9	7,0 / 1,9
MR505/506	8,5 / 1,75	-	-	8,5 / 1,75	8,5 / 1,75	-	-	11,7 / 1,75	11,7 / 1,75
MR605/606	12,5 / 3,1	-	-	12,5 / 3,1	12,5 / 3,1	-	-	18,4 / 3,1	18,4 / 3,1
MR705/706	21 / 3,1	-	-	21 / 3,1	21 / 3,1	-	-	35 / 3,1	35 / 3,1
MR875/876	35 / 3,1	-	-	35 / 3,1	35 / 3,1	-	-	45 / 3,1	45 / 3,1
MR975/976	50 / 5,5	-	-	50 / 5,5	50 / 5,5	-	-	60 / 7,0	60 / 7,0
NR275/276	-	1,85 / 0,5	1,85 / 0,5	-	-	2,0 / 0,5	2,0 / 0,5	-	-
NR285/286	-	2,85 / 0,5	2,85 / 0,5	-	-	3,0 / 0,5	3,0 / 0,5	-	-
NR375/376	-	3,3 / 0,85	3,3 / 0,85	-	-	3,4 / 0,85	3,4 / 0,85	-	-
NR475/476	-	7,6 / 1,9	7,6 / 1,9	-	-	8,0 / 1,9	8,0 / 1,9	-	-
NR505/506	-	11,7 / 1,75	11,7 / 1,75	-	-	12,8 / 1,75	12,8 / 1,75	-	-
NR605/606	-	20,1 / 3,1	20,1 / 3,1	-	-	22,5 / 3,1	22,5 / 3,1	-	-
NR705/706	-	32 / 3,1	32 / 3,1	-	-	35 / 3,1	35 / 3,1	-	-
NR875/876	-	45 / 3,1	45 / 3,1	-	-	50 / 3,1	50 / 3,1	-	-
NR975/976	-	50 / 8,0	50 / 8,0	-	-	60 / 8,0	60 / 8,0	-	-



c- Mounting Positions

B3			
B5			
B5I			
B6			
B7			
B8			

Symbols : : Drain plug : Vent plug : Oil level : Only upon request



Operating Instruction

M Series

Mounting Positions



V1			
V3			
V5			
V6			

Symbols :  : Drain plug  : Vent plug  : Oil level  : Only upon request



9- Troubleshooting Guide



All the operations bellow must be done by experienced mechanichan/electrican. Do not make anythink if you are not sure what you are doing and contact YILMAZ. Any change or operation done without the information of YILMAZ REDUKTOR is in your own risk and responsibility and YILMAZ REDUKTOR does not take any responsibility.

ID	Problem	Observation	Remedy
001	Gearbox Does Not Start Up	You hear no noise and shaft is not turning. You are not using any driver or frequency inverter.	Please Check the voltage supply and frequency of your electric connection. They must be in accordance with the nameplate of the motor. Observe motor manufacturers start up manual. Still does not work go to ID 100
002	Gearbox Does Not Start Up	You hear no noise and shaft is not turning. You are using frequency inverter or driver.	Please observe the frequency inverter/driver manual. Check the motor by supplying direct voltage to see if the problem is on your driver/frequency inverter. Still does not work go to ID 001.
003	Gearbox Does Not Start Up	You hear some noise but both motor shaft and gearbox shaft is not turning. You are not using any driver /frequency inverter or braked motor.	Please Check the voltage supply and frequency of your electric connection. They must be in accordance with the nameplate of the motor. Observe motor manufacturers start up manual. Still same problem, the load may be too high for the choosen motor. Loosen the gearbox from the load/torque. If it works than the starting torque is insufficient and higher motor power is needed. For monophaze motors, check the starting up condansator and running condansator as well. If notting helps go to ID 100
004	Gearbox Does Not Start Up	You hear some noise but both motor shaft and gearbox shaft is not turning. You are using driver or frequency inverter.	Please observe the frequency inverters or drivers manual. To see if the problem is on your driver or frequency inverter take out the driver/frequency inverter and make direct voltage supply to the motor according the motors nameplate. Still does not work go to ID 100
005	Gearbox Does Not Start Up	You hear some noise but both motor shaft and gearbox shaft is not turning. You are using braked motor	Please Check the voltage supply and frequency of your electric connection. They must be in accordance with the nameplate of the motor. Observe motor manufacturers start up manual. Be sure that the brake is working. Observe the brake manufacturers manuel. If brake is supplied from YILMAZ observe this manuel for correct brake wiring diagram. If still not work supply the brake with voltage according its nameplate directly. For example 198V DC. You will hear a clicking noise explaining that the brake is opening. If you hear no noise the brake or rectifier is defect. If you hear the clicking noise the brake is working. You should this clicking noise by your normal electric connection as well. By supplying direct supply to the brake you hear the clicking noise and at same time you supply the motor with direct voltage according to its name plate and still same problem, the load may be too high for the choosen motor. Goto ID 003.

Operating Instruction

M Series

Mounting Positions



ID	Problem	Observation	Remedy
006	Gearbox Does Not Work in Low Speeds/frequencies.	You are using frequency inverter.	For very low speeds the frequency inverters frequency is lowering down. For very low frequencies the inverter parameter and motor parameter must be optimized. Also for low speeds the efficiency of the gearbox may vary too much. Specially for worm-gearboxes. The recommended frequency range is 20-70 Hz for worm-gearboxes and 10-70 Hz for Helical Gear Boxes. Use Higher motor power and Frequency inverter or change ratio of gearbox to work inside the recommended range.
007	Gearbox Does Not Start Mornings or After Long Time Stop.	Ambient Temperature is below +5 Celsius	The oil is not in accordance with your working conditions. Change to lower viscosity oils. Observe this manual for using the correct oil. Working in higher ambient temperatures is an other solution if possible. If still same problem you need higher motor power.
008	Gearbox is Heating Up too Much	You are using Worm Gear Box and ambient temp is lower than +40 Celsius	Measure the surface temp. using a temperature measuring device under full load. If the temp is under +80 Celsius this will make no harm to the gearbox and is normal. All ATEX conforming gearboxes and standart worm gearboxes are designed to work under max. +120 Celsius. <u>If higher than +120 Celsius and using ATEX conforming gear box immediately stop the system and contact YILMAZ REDUKTOR.</u> Go to ID 100. If not ATEX confirming check the oil type and oil quantity/level according your mounting position and check the nameplate mounting position. If nameplate mounting position does not fit the actual position goto ID 100.
009	Gearbox is Heating Up too Much	You are using Helical Gear Box. Ambient temp is lower than +40 Celsius	Measure the surface temp. using a temperature measuring device under full load. If the temp is under +80 Celsius this will make no harm to the gearbox and is normal. All ATEX conforming gearboxes are designed to work under max. +120 Celsius. <u>If higher than +120 Celsius and using ATEX conforming gear box immediately stop the system and contact YILMAZ REDUKTOR.</u> If not ATEX gearbox the gearbox is designed to work under max. +80 Celsius. If higher than +80 Celsius check the oil type and oil quantity/level according your mounting position and check the nameplate mounting position. If nameplate mounting position does not fit the actual position goto ID 100
010	Gearbox is Heating Up too Much	Ambient Temp is over +40 Celsius	Standart Gearboxes are designed to work under +40 Celsius. ambient temperature. If ambient temp is higher than +40 Celsius special solutions/gearboxes are required. Please contact YILMAZ
011	Gearbox is noisy	Nois is regular continuous	Check Your moving parts for noise. Disassemble the gearbox and run without load. If you still hear the noise motor bearings or gearbox bearings are defect. Change bearings. Goto ID 100
012	Gearbox is noisy	Nois is random	Check Your moving parts for noise. Disassemble the gearbox and run without load. If you hear still the noise the oil may has some particles inside. Change the oil and look for small particles. If metal particles are found the gearbox may have some damage. Goto ID 100



ID	Problem	Observation	Remedy
013	Gearbox is noisy	Regular knocking noise	Check Your moving parts for noise. Disassemble the gearbox and run without load. If you still hear the noise one of the gears inside is defect. Goto ID 10
014	Gearbox is noisy	Regular up and down noise (Sinoidal noise)	Check the output-shaft connection elements for runout. Take out the output shaft element and run without load. If you still hear the noise one of the gears has runout problem. Goto ID 10
015	Gearbox is noisy	Gearbox is with braked motor and noise is coming from the brake side randomly.	Low randomly clicking noise may come from the brake disk which is normal. If noise level is disturbing the brake may be defect or brake clearance is not adjusted. Goto ID 100
016	Gearbox is noisy	You are using frequency inverter and the noise level is changing according your speed.	The frequency inverter parameters are not optimized for the frequency range or motor you are using. Observe the frequency inverters manual. If still same problem change the ratio of gearbox. Goto ID 100
017	Oil is Leaking	Oil Leakage from Seal	If ambient Temp is over +40 Celsius or none stop work over 16 hours please change the top plug with a breather plug. Observe this manual for using breather plug. If this is not your case the seal could be damaged. Goto ID 100
018	Oil is Leaking	Oil Leakage from Plug	If you are using breather plug be sure it is in the correct place. This is the most top plug position according your mounting position. The plug may be not tight enough. There are some particles under the plug rubber surface. Clean and tighten the plug. If still same problem goto ID 100
019	Oil is Leaking	Oil Leakage from Housing	Observe exactly where the oil is coming out. It could be seal or plug point where it comes out and leaks over the housing. If this is your case goto ID 018/019. If you are sure oil comes out from housing than housing has some micro split / crack. Goto ID 100
020	Oil is Leaking	Oil Leakage from Cover	The sealing liquid under cover is split/defect. Disassemble the cover and put new sealing liquid. Assemble the cover and tighten the bolts. If still same problem goto ID 100
021	Gearbox is moving regularly on its mounting point	You are using Torque Arm	The movement of gear box is because of the runout of the shaft which you assemble the gearbox. This has no bad affect or harm to the gearbox and is normal unless you are using torque arm.
022	Gearbox is moving randomly on its mounting point	You are using Torque Arm	The movement of gear box is because of the runout and clearance of the shaft which you assemble the gearbox. Check the clearance of the assembling shaft and the clearances on your machine. This has no bad affect or harm to the gearbox unless you are using torque arm.
023	Motor is heating up	Motor is running over its nominal current	The motor power is not enough or some overload to the motor is possible. The motor may be defect. Goto ID 100
023	Motor is heating up	Ambient is dusty	Check the motor Fan Hub and ribs. They must be free of dust. If you are using forced external fan, check if it is working. If you are using frequency inverter in low speeds and you do not have forced external fan, you may need forced external fan. Goto ID 100

Operating Instruction

M Series

Mounting Positions



ID	Problem	Observation	Remedy
024	Motor is running but Gearbox shaft does not turn	Scratchinh noise comes out	Some part (key, gear) may be defect inside gearbox. Goto ID 10
025	Gearbox Housing is Defect	You are using chain drive or pinion gear	The radial load or poligon effect of the chain may have caused the damage. Check also if the assembly bolts are loosened or the plate you assemble the gearbox is rigit enough. Check if you are using the correct diameter of chain drive and you are not exceeding max. allowed radial load. Check the position of your output element and re-calculate your radyal load and check if this fit to tha maximum allowed radial bad. Goto ID 100
026	Output Shaft is Defect	You are using chain drive or pinion gear	The radial load or poligon effect of the chain may have caused the damage. Check also if the assembly bolts are loosened or the plate you assemble the gearbox is rigit enough. Check if you are using the correct diameter of chain drive and you are not exceeding max. allowed radial load. Check the position of your output element and re-calculate your radyal load and check if this fit to tha maximum allowed radial bad. Goto ID 100
027	Gearbox is stopping too late	You are using braked motor	Please check the wiring diagram of the brake. There are two different kind of brake wiring diagram. The standart gearbox delivered from our factory is set to delayed braking. For sudden braking check the wiring diagram.
028	Gearbox is starting too late	You are using braked motor	For fast opening of big brakes (over 100Nm), you may need shock transformators which is supplied by YILMAZ. Goto ID 100
100	Service Required	No self solution found	Please contact YILMAZ REDUKTOR Service point. See on the back side of this manual



Yilmaz Reduktor San. ve Tic. A.S.

Head Office: Maltepe Gumussuyu Cad. Bestekar Medeni Aziz Efendi Sok. No:54 P.K.34020 Topkapi/Istanbul-TURKEY
Tel: +90 (0) 212 567 93 82/83 , Fax: +90 (0) 212 567 99 75

Factory: ATATURK mah. Lozan Cad. No:17 P.K.34522 Esenyurt-Istanbul- TURKIYE
Phone: +90 (0) 212 886 90 01 - 6 line , Fax: +90 (0) 212 886 54 57

DECLARATION BY THE MANUFACTURER
(According 94/9/EC, Anex VIII)

We **YILMAZ REDÜKTÖR Sanayi ve Ticaret A.Ş.**
ATATÜRK mah. Lozan Cad. No:17 P.K.34522 Esenyurt-İstanbul- TURKIYE
Phone: +90 (0) 212 886 90 01 - 6 line , Fax: +90 (0) 212 886 54 57

herewith declare, on our own responsibility, that the following products

MN/NN/MT/NT Series Gear Units
Ex II 2GD c,k T4 / T120 C

in catagorie 2G and 2D that are subject to this decleration are meeting the requirements
set forth in

Directive 94/9/EC

Applicable standarts: EN 1127-1, EN 13463-1, EN 13463-5, EN 13463-8

**The product this declaration refers to must not be put into service until the machin-
ery into which it is to be incorporated has been declared in conformity with the
provisions of the relevant European Directives.**

YILMAZ REDUKTOR will archive the documents required according to 94/9/EC, Appendix
VIII
at the following location

TÜV Product Service No: 0123
with file No: Ex 8 05 04 54878 012

TURKEY / Istanbul
Date : 01.01.2005

Authorized Person
Re-Search Manager
Metin YILMAZ

This declaration is not guarantee of charecteristics in the sense of the product liability law.
The safety regulations of the maintenance instructions have to be observed.



Warranty Conditions:

1. The geared motors and gear units are warranted for two year except the electric motor. For motor warranty please refer to the manual of the electric motor manufacturer or the warranty document of the motor manufacturer. This warranty is valid only if the gearbox is assembled and started up according our operating instructions and is used under the allowed conditions for the appropriate gearbox type in our catalogue.
2. The warranty time starts from the start up time written on the warranty document and last for two years. If the start-up time is more then three months after the billing time, the total warranty time is limited to 27 months starting from billing time. If the warranty document is not send to our company after start-up, the total warranty time will be limited to 24 months after the billing time.
3. Any time during the warranty for maintenance, repair or change will be added to the warranty time. This time starts from the date which the company or representative was made aware of the problem and ends on the date of the re-start-up.
4. If the product fails to operate because of a manufacturing or assembly failure during the warranty time, the product will be repaired free of charge.
5. If the product fails to operate because of a manufacturing or assembly failure during the warranty time and it is not possible to repair it, the product will be changed with a new one according to the report from our service department mentioning that the hazard can not be repaired.
6. Costumers must inform the manufacturer if there are some problems after the service and repair of the failed product.
7. The extra costs like stopped plant, physical or mental injuries etc. by the costumer side are not covered by this warranty except the product itself.

Yılmaz Redüktör San. ve Tic. A.Ş.

Head Office: Maltepe Gümüşsuyu Cad. Bestekar Medeni Aziz Efendi Sok. No:54
P.K.34020 TOPKAPI-İSTANBUL-TURKEY Phone: +90 (0) 212 567 93 82/83 , Fax: +90
(0) 212 567 99 75

Factory : ATATÜRK mah. Lozan Cad. No:17 P.K.34522 Esenyurt-İstanbul- TURKİYE
Phone: +90 (0) 212 886 90 01 - 6 line , Fax: +90 (0) 212 886 54 57



Warranty

YILMAZ REDÜKTÖR products are **warranted for 2 (Two) years** covering all parts and materials used in products and their production errors unless they are started-up and used according our service manual and is not modified or disassembled without an acknowledgement from our company.

The warranty covers all costs like repair, service, spare parts etc. and no charge will be asked under any name. The time for repair, service will be added to the warranty time.

For detailed warranty conditions please refer the back side of this page.

Serial No:

Type:

Manufacturer:

Company : YILMAZ REDÜKTÖR SANAYİ VE TİCARET A.Ş.
Address : Gümüşsuyu Cad. Bes.Medeni Aziz Efendi Sok. No:54
Topkapı / Maltepe / İsyambul / TURKEY
Phone : +90 (0) 212 567 93 82 / 83 - +90 (0) 212 886 50 43/44
Fax : +90 (0) 212 567 99 75 - +90 (0) 212 886 54 57

Stamp and Signature

Supplier / End User:

Name:

Billing Date/ Bill No.:

Start-Up Place / Date:

Address:

Phone - Fax:

Supplier/ End User Stamp and Signature

Service Contact Points:

Main Service Point:

YILMAZ REDÜKTÖR A.S.

ATATÜRK mah. Lozan Cad. No:17 P.K.34522 Esenyurt-İstanbul- TURKİYE

Phone: +90 (0) 212 886 90 01 - 6hat , Fax: +90 (0) 212 886 54 57

Head Office:

Phone:+90 (0)212 567 93 82 (2 line),

+90(0) 212 567 06 03,

+90(0) 212 567 40 78

+90(0) 212 567 04 11

+90(0) 212 567 45 07

+90(0) 212 567 00 70

Fax: +90(0) 212 567 99 75

e-mail: yilmaz@yr.com.tr

web: www.yr.com.tr

Factory:

Phone:+90(0) 212 886 61 92 (5 lines)

+90(0) 212 886 50 43

+90(0) 212 886 50 44

+90(0) 212 886 52 82

Fax: +90 (0) 212 886 54 57

e-mail: yilmaz@yr.com.tr

web: www.yr.com.tr

Outside Turkey:

Please contact the main service point mentioned above. You will be directed to our nearest service point to your location